



# CX826

## 8 inch Coaxial Loudspeaker

*tq*install™  
SERIES



### Overview

The CX826 is a coaxial loudspeaker that provides the output capability of a traditional 8 inch 2-way, horn-loaded-HF loudspeaker, but in a much more compact enclosure. Its coaxial transducer and 120° x 60° horn can be rotated in 45° increments, which allows its coverage to be tailored to best suit an application's requirements. The enclosure's vertically trapezoidal shape allows it to be installed very close to ceilings or beneath large arrays with minimal effect on sight lines. Its unusually broad pattern is uniquely suited for use as the center channel in L-C-R systems, to solve difficult fill problems, and in many other applications.

Fulcrum Acoustic's **TQ™** processing is an integral part of the CX826 design. Sound, innovative acoustical design combined with state of the art digital processing leads to exceptional clarity and precise transient response, even at very high sound pressure levels. The required digital signal processing can be provided by one of many supported platforms.

The CX826 is particularly effective for fill systems where targeted pattern control is desirable. In addition, its 16 ohm nominal impedance makes it an excellent solution for high fidelity, foreground distributed systems where a high loudspeaker-to-amplifier ratio is desirable. Its unique shape and compact size complements many architectural styles, which facilitates acceptance by interior designers and architects. This makes it the perfect choice for houses of worship, theaters, restaurants, transportation facilities, theme parks, and more.

### Performance Specifications<sup>1</sup>

#### Operating Mode

Single-amplified w/ DSP

#### Operating Range<sup>2</sup>

78 Hz to 20 kHz

#### Nominal Beamwidth (rotatable)

120° x 60°

#### Transducers

HF/LF: Coaxial 1.7 inch titanium diaphragm compression driver; 8.0 inch woofer, 2.0 inch voice coil; single neodymium magnet

#### Power Handling @ Nominal Impedance<sup>3</sup>

63 V / 250 W @ 16 Ω

#### Nominal Sensitivity @ Input Voltage<sup>4</sup> (whole space)

102 dB @ 4.00 V

#### Nominal Maximum SPL (peak / continuous)

132 dB / 126 dB

#### Equalized Sensitivity @ Input Voltage<sup>5</sup>

94 dB @ 4.00 V

#### Equalized Maximum SPL<sup>6</sup> (peak / continuous)

124 dB / 118 dB

#### Recommended Power Amplifier

250 W to 500 W @ 16 Ω

### Physical Specifications

#### Connections

(2) Neutrik NL4 Speakon

Pin 1+/-: Full Range

Pin 2+/-: NC

#### Mounting / Suspension Points

(2) M6 x 1.0 yoke points, (2) M6 x 1.0 pull back points

#### Dimensions / Weight

See page 5

#### Finish

Black painted enclosure w/ matte black grille, or

White painted enclosure w/ matte white grille

#### Options

YK-CX8 yoke bracket, Terminal strip input, Custom color finish, Weather-resistant (WR) enclosure & hardware



Axial Sensitivity (dB SPL, 4.00 V @ 1 m)<sup>7,8</sup>

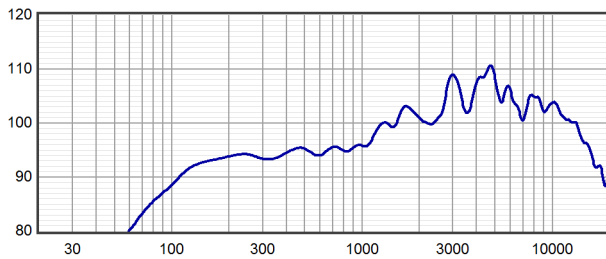

Horizontal Off Axis Response<sup>7,11</sup>

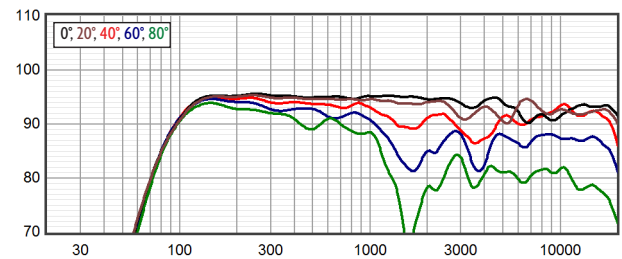

Axial Processed Response (dB)<sup>7,9</sup>

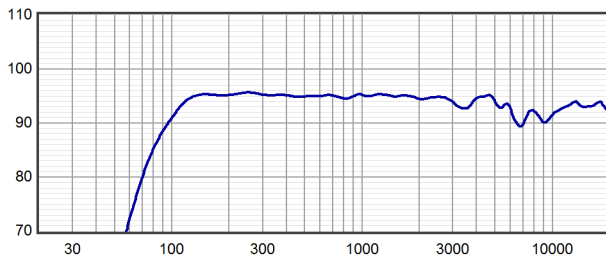

Vertical Off Axis Response<sup>7,11</sup>

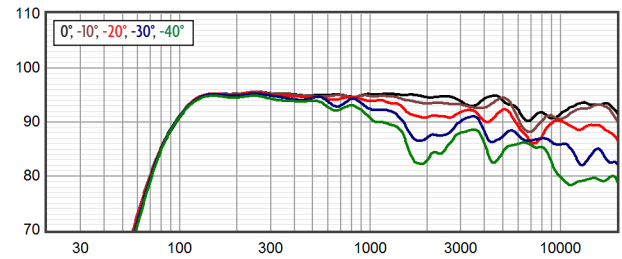

Axial Processed Phase Response (degrees)<sup>7,10</sup>

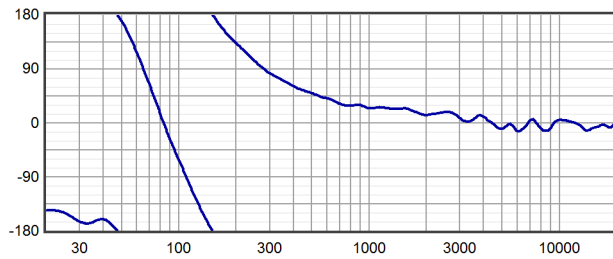

Beamwidth<sup>7,12</sup>

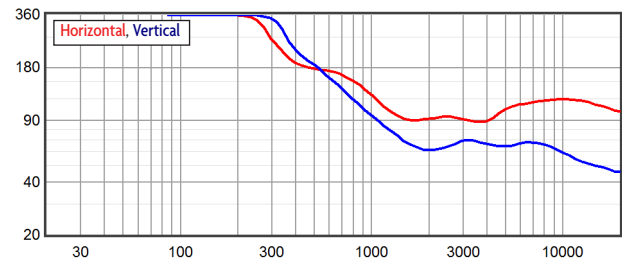

Impedance (ohms)

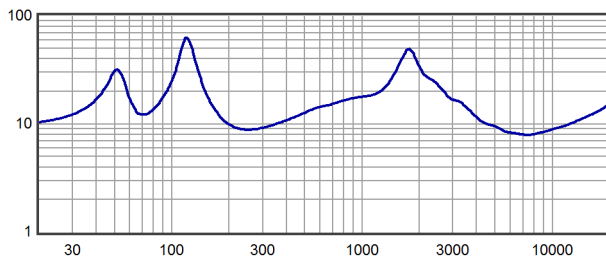

Directivity Index (dB)<sup>13</sup>

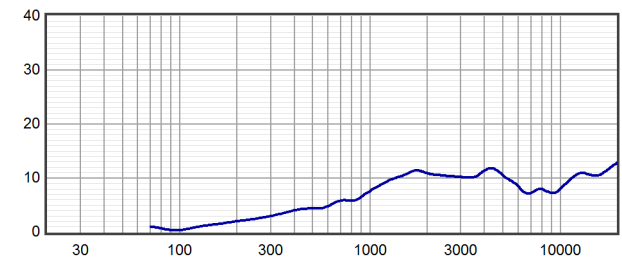



Horizontal Polar Response (30 dB Scale, 6 dB per Major Division)

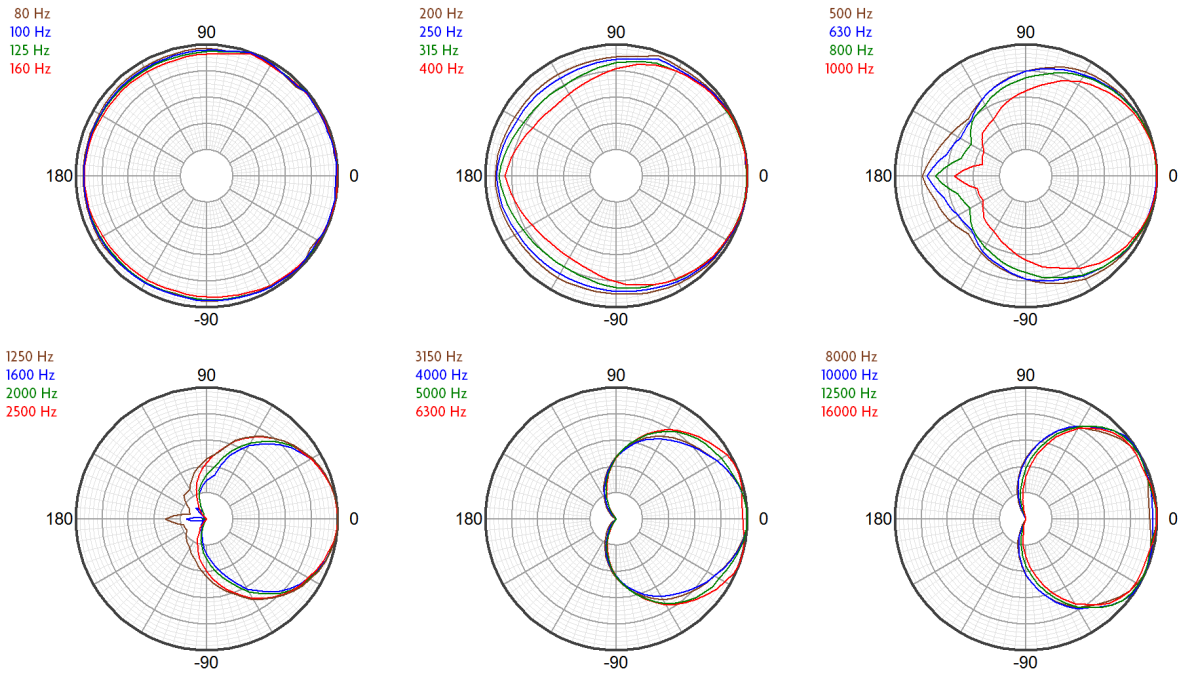

Vertical Polar Response (30 dB Scale, 6 dB per Major Division)

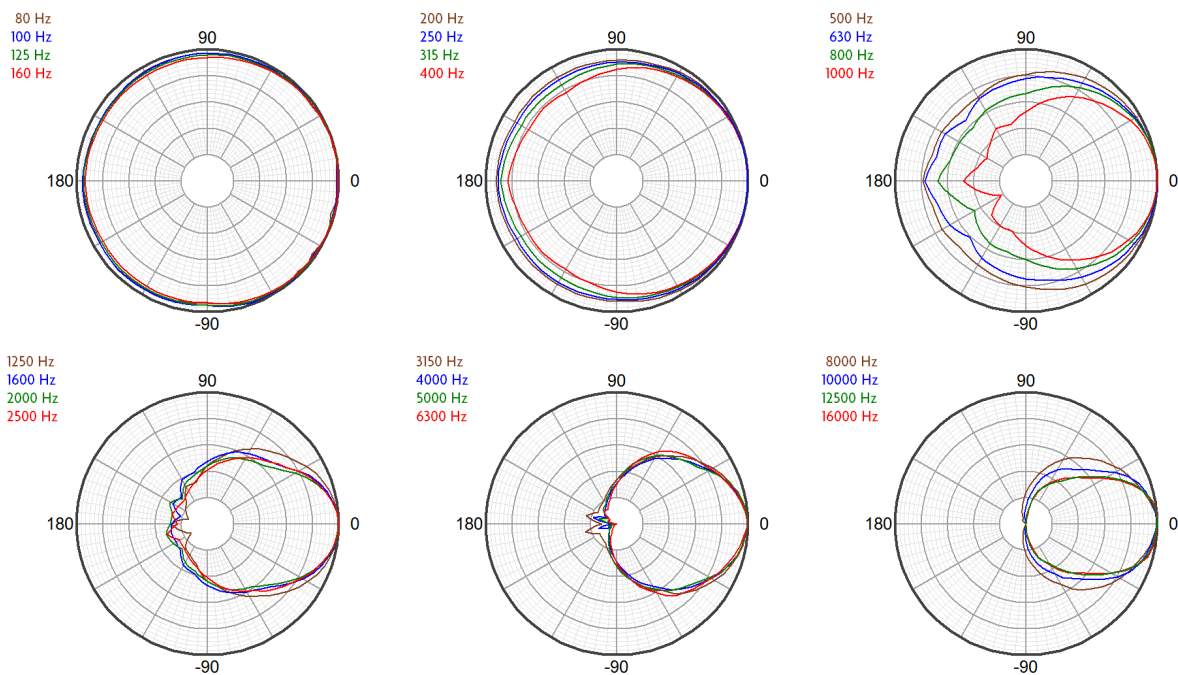



### Technologies

The CX826 includes a neodymium-based coaxial transducer which allows the compression driver diaphragm to be positioned very close to the woofer voice coil. This allows the system to maintain coherent summation and consistent off axis response through a passive crossover, allowing it to be powered with a single amplifier channel.

The compression driver's 1.75 inch diameter diaphragm operates

to a relatively low frequency. This allows the high frequency horn to smooth the polar response of the low frequency section in the frequency range where the horn would otherwise cause shadowing. The coaxial woofer's large radiating surface works in conjunction with the HF horn to improve directional control at the low frequency limit of the horn's operating range, increasing directional control beyond what can be accomplished by the horn alone.

### Connection Diagram

2-way, Single-Amp

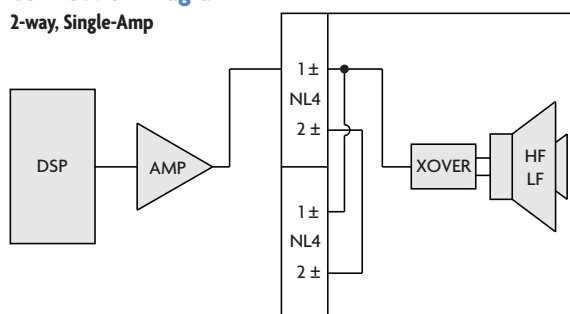

### Mechanical Specification Drawings

2D and 3D DWG dimensional drawings are available for download at [www.fulcrum-acoustic.com/support](http://www.fulcrum-acoustic.com/support).



### Notes

- <sup>1</sup> **Performance Specifications** All acoustic specifications rounded to nearest whole number. External DSP with Fulcrum Acoustic-provided settings is required to achieve the specified performance.
- <sup>2</sup> **Operating Range** The frequency range within which the processed response is within 10 dB of the average.
- <sup>3</sup> **Power Handling** Based on the AES power handling of the transducers.
- <sup>4</sup> **Nominal Sensitivity** The 1-meter-referenced SPL produced by a 1 watt band limited pink noise signal, with no processing applied.
- <sup>5</sup> **Equalized Sensitivity** The 1-meter-referenced SPL produced when an EIA-426-B signal is applied to an equalized loudspeaker system, at a level which produces a total power of 1 watt, in sum, to the loudspeaker subsections.
- <sup>6</sup> **Equalized Maximum SPL** The 1-meter-referenced SPL produced when an EIA-426-B signal is applied to an equalized loudspeaker system, at a level which drives at least one subsection to its rated power.
- <sup>7</sup> **Resolution** All response graphs are subjected to 1/6 octave cepstral smoothing with a gaussian weighting function.
- <sup>8</sup> **Axial Sensitivity** The SPL plotted against frequency for a 1 watt swept sine wave, referenced to 1 m with no signal processing.
- <sup>9</sup> **Axial Processed Response** The axial magnitude response with recommended signal processing applied.
- <sup>10</sup> **Axial Processed Phase Response** The axial phase response with recommended signal processing applied, and latency removed.
- <sup>11</sup> **Horizontal / Vertical Off Axis Responses** The magnitude response at various angles off axis, with recommended signal processing applied.
- <sup>12</sup> **Beamwidth** The angle between the -6 dB points in a loudspeaker's polar response.
- <sup>13</sup> **Directivity Index (Di)** The ratio of the on-axis sound pressure squared to the spherical average of the sound pressure squared at a particular frequency expressed in dB. To convert the directivity index to directivity factor (Q) use the formula  $10^{Di/10}$ .



product specification

Notes:

1. Net Weight = Approx. 17.0 lb / 7.7 kg
2. Ship Weight = Approx. 22.0 lb / 10.0 kg
3. Symbol  = M6 nut plate
4. Symbol  = CoG
5. Drawing representative of:  
CX896, CX826

REVISIONS

REV	DESCRIPTION	APPR / DATE
1	RELEASE TO PRODUCTION	RAF 11/6/09
2	CORRECT REAR HEIGHT DIMENSION	RAF 12/11/09
3	ADD SHIPPING WEIGHT	RAF 12/5/11
4	OMNIMOUNT TO "THIRD PARTY" IN NOTE 4	RAF 1/13/12
5	REMOVE PAN/TILT MOUNT POINTS	RAF 7/28/16
6	UPDATE DWG NAME TO CX8 SERIES	RAF 3/23/18
7	ADD AFFECTED MODELS TO NOTES	RAF 7/17/18

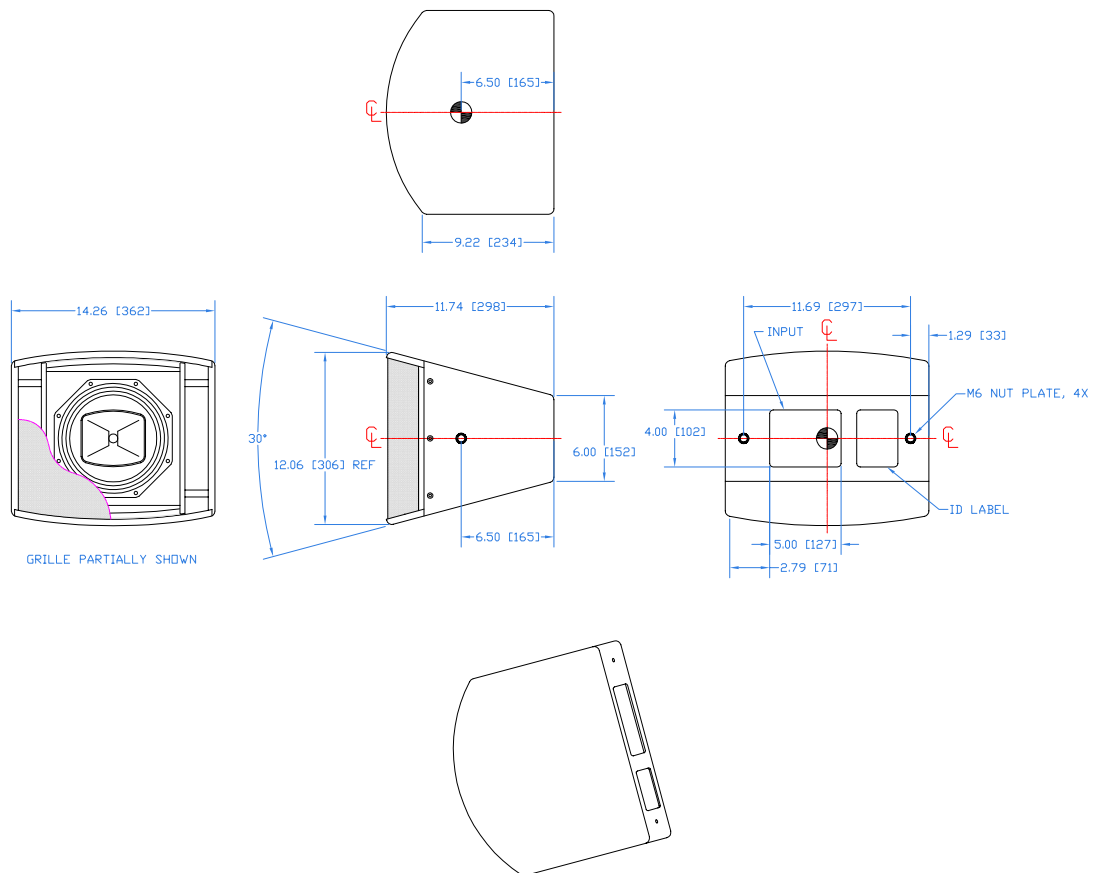

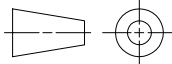
<p>THIRD ANGLE PROJECTION</p> 	<p>UNLESS OTHERWISE SPECIFIED: ALL DIMENSIONS ARE IN INCHES</p> <p>TOLERANCE IN INCHES .XX±.015 .XXX±.005 FRACTIONS ±1/32 ANGLES ±1/2°</p> <p>(X.XX) = REF DIMS NO TOLERANCE IMPLIED</p> <p>TSC = THEORETICAL SHARP CORNER</p> <p>DIMENSIONS ACROSS CENTERLINES TO BE SYMMETRICAL</p>	<p>STATUS RELEASED</p>		<p>FULCRUM ACOUSTIC, LLC 670 LINWOOD AVE, LINWOOD, MA 01525 USA</p>
		<p>APPROVALS</p> <p>DRAWN: DWG</p> <p>CHECKED: RAF</p> <p>DES ENG:</p> <p>MFG ENG:</p>	<p>DATE</p> <p>2/10/09</p> <p>6/12/09</p>	
<p>THIS DRAWING IS THE PROPERTY OF FULCRUM ACOUSTIC, AND SHALL NOT BE COPIED, REPRODUCED, OR USED AS THE BASIS FOR MANUFACTURE OR SALE OF APPARATUS WITHOUT WRITTEN AUTHORIZATION. DO NOT SCALE DRAWING.</p>		<p>DWG. NO. 820-100-026</p>	<p>SCALE: 1:12</p> <p>REV 7</p>	

Drawing is reduced. Do not scale.



product specification, weather-resistant (WR) version

Notes:

1. Net Weight = Approx. 17.5 lb / 7.9 kg
2. Ship Weight = Approx. 22.5 lb / 10.2 kg
3. Symbol = M6x1.0 nut plate
4. Symbol = CoG
5. Enclosure construction: PVC
6. Drawing representative of:  
CX896-WR, CX826-WR

REVISIONS		
REV	DESCRIPTION	APPR / DATE
1	NEW ISSUE	RAF 3/19/15
2	ADD COVER PLATE DETAIL	RAF 12/01/15
3	REMOVE PAN/TILT MOUNT POINTS	RAF 7/28/16
4	UPDATE DWG NAME TO CX8 SERIES - WR	RAF 3/23/18
5	ADD ENCLOSURE MATERIAL TO NOTES	RAF 7/17/18
6	MOVE INPUT, ADD ID LABEL RECESS	RAF 1/15/21

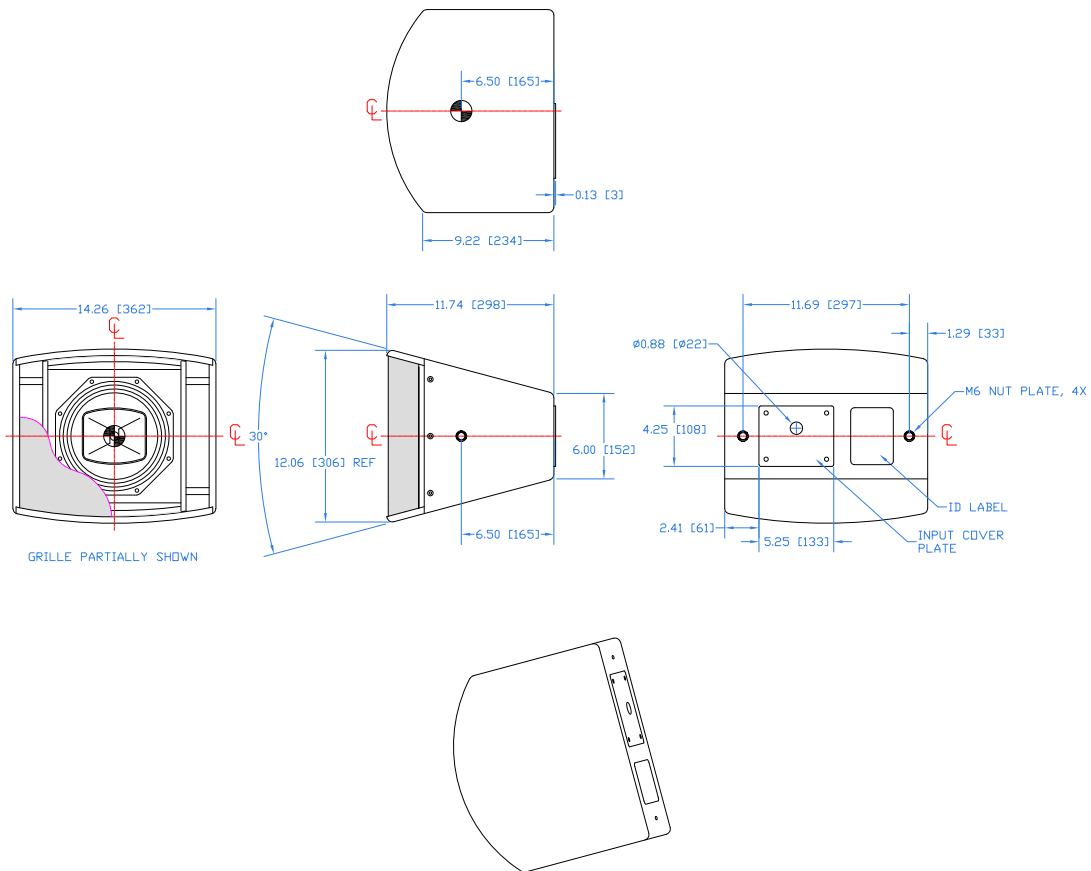

THIRD ANGLE PROJECTION 	UNLESS OTHERWISE SPECIFIED: ALL DIMENSIONS ARE IN INCHES  TOLERANCE IN INCHES .XX±.015 .XXX±.005 FRACTIONS ±1/32 ANGLES ±1/2°  (XXX) = REF DIMS NO TOLERANCE IMPLIED TSC = THEORETICAL SHARP CORNER DIMENSIONS ACROSS CENTERLINES TO BE SYMMETRICAL	STATUS RELEASED		FULCRUM ACOUSTIC, LLC 670 LINWOOD AVE., LINWOOD, MA 01525 USA
		APPROVALS	DATE	
THIS DRAWING IS THE PROPERTY OF FULCRUM ACOUSTIC, AND SHALL NOT BE COPIED, REPRODUCED, OR USED AS THE BASIS FOR MANUFACTURE OR SALE OF APPARATUS WITHOUT WRITTEN AUTHORIZATION. DO NOT SCALE DRAWING.		DRAWN: RAF	3/19/15	Mechanical Spec, CX8 Series - WR
		CHECKED: DWG	3/19/15	SHEET 1 OF 1 SCALE: 1:12
		DES ENG:		DWG. NO. 820-100-084
		MFG ENG:		REV 6

Drawing is reduced. Do not scale.

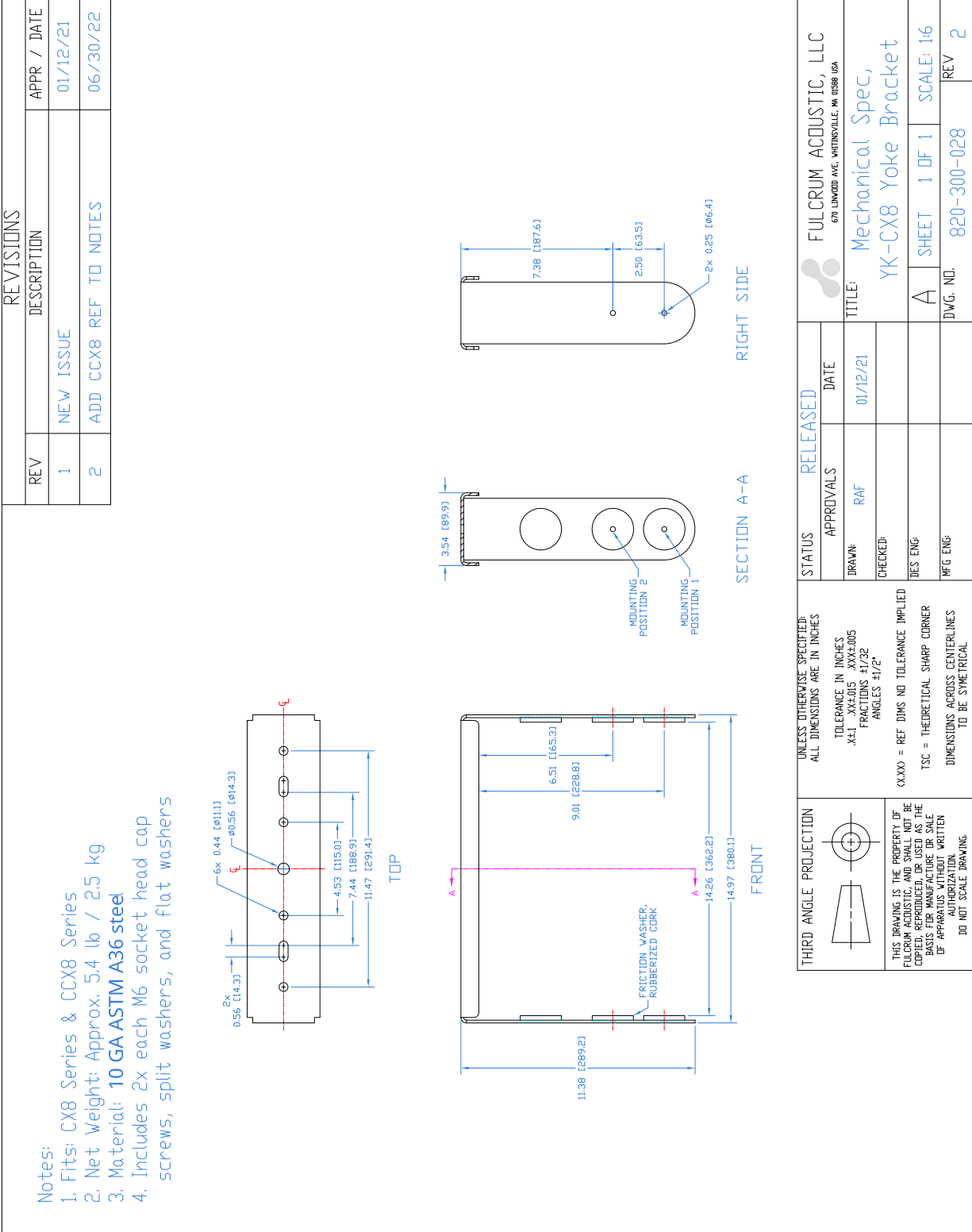

Drawing is reduced. Do not scale.

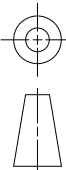
THIRD ANGLE PROJECTION		UNLESS OTHERWISE SPECIFIED: ALL DIMENSIONS ARE IN INCHES TOLERANCE IN INCHES .XX1 XX&0.05 .XX&0.005 FRACTIONS ±1/32 ANGLES ±1/2° (X.XX) = REF DIMS NO TOLERANCE IMPLIED TSC = THEORETICAL SHARP CORNER DIMENSIONS ACROSS CENTERLINES TO BE SYMMETRICAL	STATUS: <b>RELEASED</b> APPROVALS: <b>RAF</b> DRAWN: <b>RAF</b> CHECKED: DES'G ENG: MFG ENG:	DATE: 01/12/21
THIS DRAWING IS THE PROPERTY OF FULCRUM ACOUSTIC, AND SHALL NOT BE COPIED, REPRODUCED, OR USED AS THE BASIS FOR MANUFACTURE OR FOR ANY OTHER PURPOSES WITHOUT THE WRITTEN AUTHORIZATION OF FULCRUM ACOUSTIC. DO NOT SCALE DRAWING.		FULCRUM ACOUSTIC, LLC 670 LINDOOD AVE. WHTINSVILLE, IN 46088 USA		
TITLE: <b>Mechanical Spec,                  YK-CX8 Yoke Bracket</b>		A SHEET 1 OF 1 SCALE: 1:6 DWG. NO. 820-300-028 REV 2		

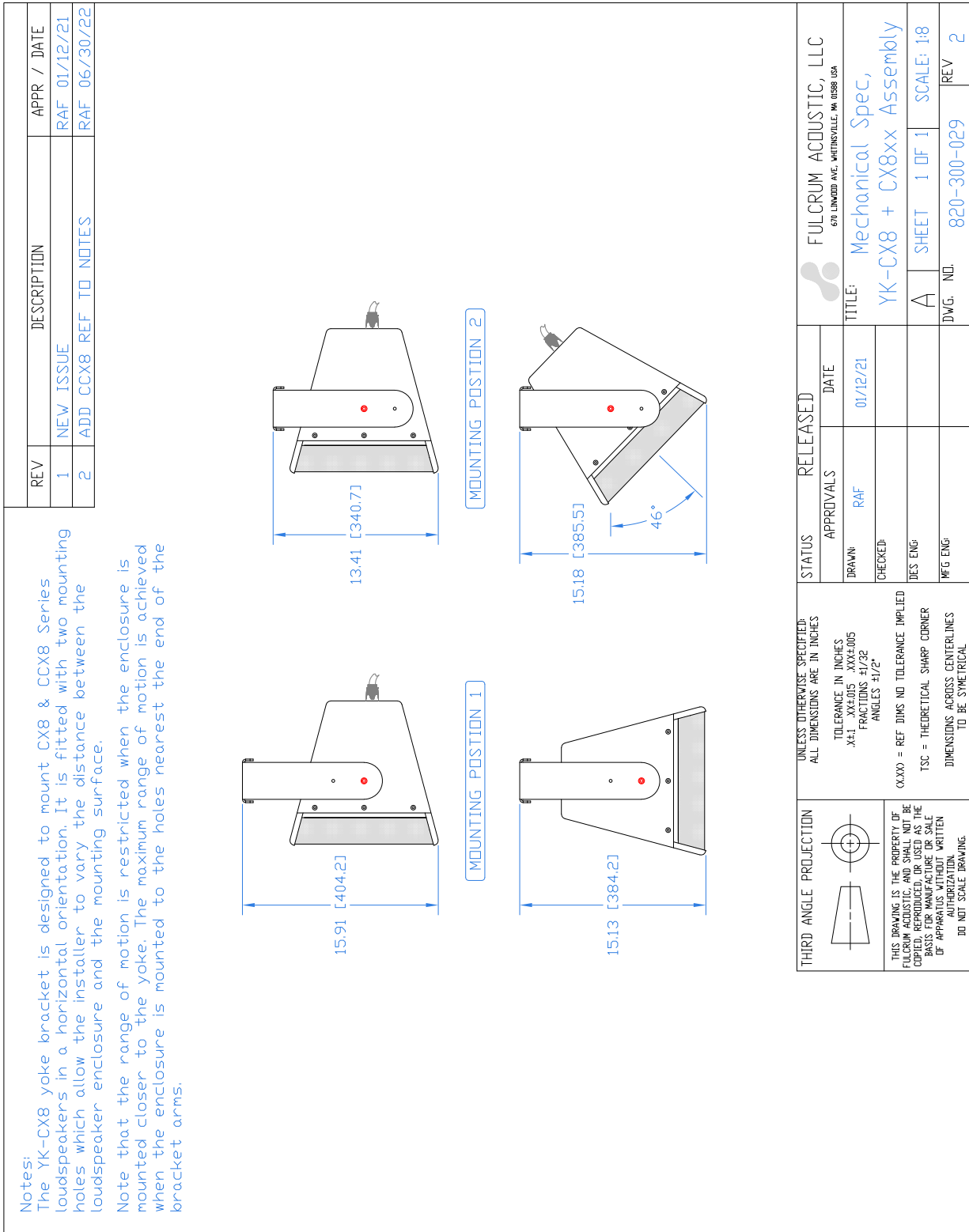

Drawing is reduced. Do not scale.